

“ArmoDock Solutions”

Easy, Safe, Solid.



Minidock – Steel and Aluminum Levellers
Options for Loading Bays





Armo s.p.a. has developed day by day the quality of its production, the efficiency of its industrial organization and the experience of its staff. Mini dock levellers, manual levellers and accessories for loading bays are built, set up and checked in Italy: a product with all the features of quality typical of **MADE IN ITALY**.



Certificated

All Armo equipment is rigorously and repeatedly tested in our factories, and, if forseen, they are CE marked.



Guaranteed

All products are covered by a 24 months warranty, starting from the delivery date. The warranty can be extended.



Insured

ARMO is covered by a liability Insurance Policy for Industrial Companies.

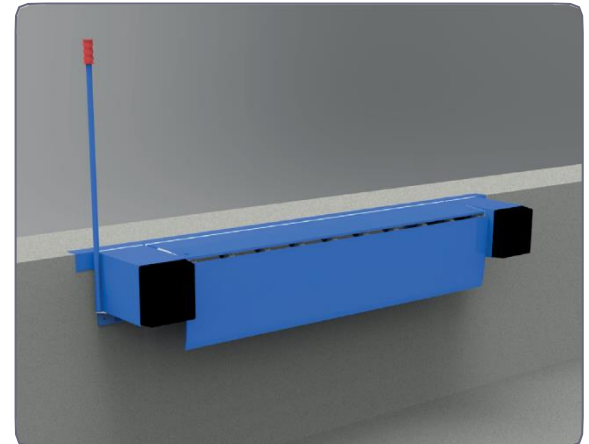

MINIDOCK

The Mini Dock is a manual operating with capacity 60 kN and hinged lip.

Main features

Armo **Mini Dock leveller** is the appropriate alternative to the classic Hydraulic Leveller to compensate small differences in height in a simple way and economically interesting, as well as loading trucks. Armo **Mini Docks** foreseen with bumpers as a standard option: the lip with length 350 mm, is designed to always have a free space to lean against the bed truck. All Armo's loading levellers are made in accordance to the EN 1398 rule. Standard color: RAL 9005 BLACK. Options: HOT-DIP GALVANIZATION – RAILINGS.

How does it work?

The operator on the dock edge manually opens the **Armo Mini Dock** pulling the standard lever and as soon as the frame gets open, the lip is extended automatically. Thanks to the lever, the frame opens, goes down and rests against the bed of the truck. During the loading/unloading operations, the leveller will follow the truck's movements automatically. At the end of those operations, the leveller must return in its normal rest position, by acting on the lever.

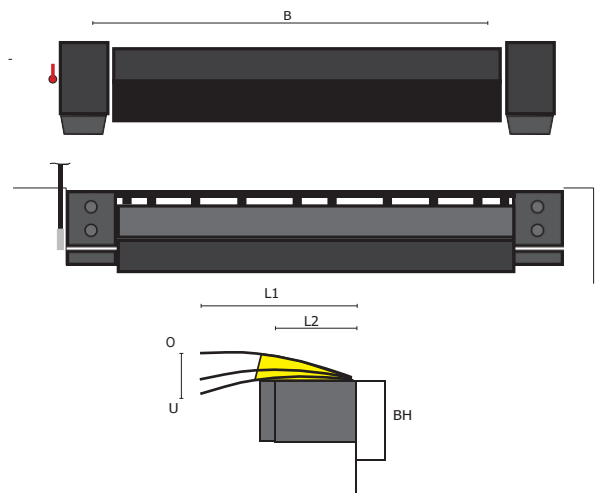

CODE	DIMENSIONS in mm					
Front installation	B	L 0	L 1	L 2	BH	O = U
Mini-2000	2000	470	720	370	384	100

Variant available on request

LIGHT- ALLOY LEVELLERS AT THE EDGE OF THE DOCK

AR-KBS

CODE	DIMENSIONS		WORKING RANGE		CAPACITY kg
	length	X width	min.	max.	
AR-KBS.21.000	410	x 1250	- 70	+ 30	4000
AR-KBS.21.012	535	x 1250	- 90	+ 45	4000
AR-KBS.21.013	785	x 1250	- 120	+ 75	4000
AR-KBS.21.002	910	x 1250	- 135	+ 90	4000
AR-KBS.21.004	410	x 1500	- 70	+ 30	4000
AR-KBS.21.014	535	x 1500	- 90	+ 45	4000
AR-KBS.21.015	785	x 1500	- 120	+ 75	4000
AR-KBS.21.006	910	x 1500	- 135	+ 90	4000
AR-BSFV.23.006	Steel not painted rail with length 1000 - 2000 - 3000 mm				
AR-BSFZ.23.016	Galvanized rail with length 1000 - 2000 - 3000 mm				

AR- KBS Light-Alloy Levellers: they are levellers, which moves through a steel welded rail at the top of the dock. In their rest position, they are vertical oriented and ensured avoiding a potential fall thanks to a block (EN 1398), but they could also be placed in vertical position at the edge of the dock. Due to the stress limits of the ergonomic lifting of 30 kg, the AR-KBS are available up to the maximum size indicated in the chart.

AR-SKBS

AR-SKBS Light-Alloy Levellers: Due to the stress limits of the ergonomic lifting of 30 kg, all fixed and sliding light-alloy levellers operate manually with a safety block, up to maximum length of 815 mm, and springs screw up to a maximum length of 1565 mm. All levellers are provided with a vertical safety block system. Armo's light-alloy levellers are also equipped with a maneuvering bar, which is integrated to the leveller and placed to its lateral side.

CODE	DIMENSIONS		WORKING RANGE		CAPACITY kg
	length	X width	min.	max.	
AR-SKBS.20.011	815	x 1250	- 120	+ 80	4000
AR-SKBS.20.012	1315	x 1250	- 185	+ 140	2500
AR-SKBS.20.013	1565	x 1250	- 215	+ 175	1750
AR-SKBS.20.014	565	x 1500	- 90	+ 50	4000
AR-SKBS.20.015	815	x 1500	- 120	+ 80	4000
AR-SKBS.20.016	1065	x 1500	- 155	+ 110	4000
AR-SKBS.20.017	1315	x 1500	- 185	+ 140	4000
AR-SKBS.20.018	1565	x 1500	- 215	+ 175	4000
AR-SKBS.22.002	Not painted rail with length 2000 - 3000 mm				
AR-SKBS.23.007	Galvanized rail with length 2000 - 3000 mm				



AR-KBS



AR-SKBS



AR-FBS

BALANCED STEEL LEVELLERS AT THE EDGE OF THE DOCK

Steel levellers RAL 5010, capacity kg. 5000-6000: Thanks to the springs screw, the horizontal and vertical position are perfectly balanced, even in case of considerable weights. This enables to use, due to their dimensions, steel levellers with a capacity of 5000 kg and 6000 kg. All levellers are provided with a mechanical safety block system in their vertical rest position. The maneuver is made thanks to a bar, which in its rest position is placed to the side of the leveller: the ergonomic stress is within 30 kg.

Options: hot-dip galvanization, sector lips for lateral inclination.

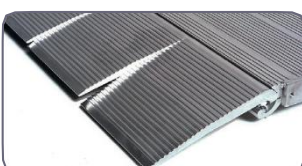

Lateral adaptation to the truck's inclination: the levellers larger than 1750 mm must follow the lateral inclination of the vehicle. This could be difficult for the balanced levellers because of the lack of the own weight. To solve this problem, all our levellers could be purchased with the option light-alloy "sectors lip".

FIXED leveller		AR-FBS.20			
SLIDING leveller		AR-FBS.21			
CODE	DIMENSIONS		W.RANGE		CAPACITY kg
	length	X width	min.	max.	
.002	1500	x 1750	- 190	+ 140	5000
.003	1500	x 2000	- 190	+ 140	5000
.004	1750	x 1500	- 220	+ 175	5000
.005	1750	x 1750	- 220	+ 175	5000
.006	1750	x 2000	- 220	+ 175	5000
.007	2000	x 1500	- 250	+ 205	5000
.008	2000	x 1750	- 250	+ 205	5000
.009	2000	x 2000	- 250	+ 205	5000
AR-SFV.22.000	Steel not painted rail with length 1000 - 2000 - 3000 mm				
AR-SFZ.23.001	Galvanized rail with length 1000 - 2000 - 3000 mm				

ACCESSORIES FOR LOADING BAYS:



Protections



Wheel alignment guides



Led traffic lights



Traffic light logic



Dock Light



Jumbo bumpers



Radar System



ArmoStop

Armo s.p.a.

Registered Office: Via Rosa di Luxemburg, 1
10093 Collegno (TO) - Italy

Operational Office: Via Vittime di Bologna
10/16 10060 None (TO) - Italy

Capital Share € 1.000.000 i.v.
c.c.i.a.a. n.667754
Registro società n. 4136/85
VAT # 04873070017

Tel. +39.011.71760.11
Fax +39.011.71760.19

e-mail: info@armoweb.com
www.armoweb.com

Armo is also...

- Dock levellers
- Tailor-made Lifting tables
- Maintenance & Service
- Industrial Doors
- Residential Sectional Doors

Ask our partner

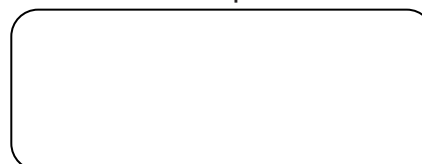

Armo spa may at any time and without any notice or obligation, change the specification of the goods presented in this leaflet.